



Search Motor - Volume : Speed Controller (SR CE TYPE)

**SPEED CONTROLLER (SR CE TYPE)**

- 1. CHARACTERISTICS
- 2. SPECIFICATION
- 3. DIMENSIONS
- 4. SCHEMATIC DIAGRAM
- 5. CAD File Download
- 6. Catalogue Download

**1. CHARACTERISTICS**

- Speed controller SR series are developed by the demands of speed variation.
- It uses the IC circuit that our company independently developed and is small, light weight and reliability.
- With acquisition of CE Mark certification, the product guarantees higher reliability.
- The rotating speed of the motor may be adjusted by a speed control variable resistor located at the front of the case and can also operate long-range by an extra speed setter.
- Increase of instantaneous stop function by electromagnetic brake.
- Miniaturized type with 11 pin plug.

The product acquired CE mark  
(File NO. E9766429E01, Certificate Institute:TÜV Rheinland)

TOP

**2. SPECIFICATION**

SPEC	MODEL	SR CE TYPE									
		SRA01CE	SRA02CE	SRB01CE	SRB02CE	SRC01CE	SRC02CE	SRD01CE	SRD02CE	SRX01CE	SRX02CE
Rated Voltage		AC 110V 60Hz		AC 220V 60Hz		AC 100V 50/60Hz		AC 200V 50/60Hz		AC 220~240V 50Hz	
Operation Voltage Range		±10%									
APPLICABLE MOTOR OUTPUT	INDUCTION	6W	15W ~ 90W	6W	15W ~ 90W	6W	15W ~ 90W	6W	15W ~ 90W	6W	15W ~ 90W
	REVERSIBLE	6W	15W ~ 40W	6W	15W ~ 40W	6W	15W ~ 40W	6W	15W ~ 40W	6W	15W ~ 40W
	E - S	6W	15W ~ 90W	6W	15W ~ 90W	6W	15W ~ 90W	6W	15W ~ 90W	6W	15W ~ 90W
Speed control range		50Hz : 90 ~ 1400 rpm				60Hz : 90 ~ 1700 rpm					
Speed variation		5% (standard)									
Speed setting device		Built in external speed setting device attachable									
Braking		Possible to stop brake for certain period by electric brake									
Braking period		0.5 sec (standard)									
Parallel operation		Not suitable for parallel operation									
Slow Run, Slow Stop		none									
Operation Temperature		-10 ~ 50°C									
Storage Temperature		-20 ~ 60°C									
Ambient humidity		85% Maximum (non condensing)									

× 1 : Suitable motors are Socket Type Speed Control Motor of ours, (Use for 12V motor T,G)

× 2 : The electric brake does not have holding torque.

TOP

**3. DIMENSIONS**

**SR CE TYPE SPEED CONTROLLER**

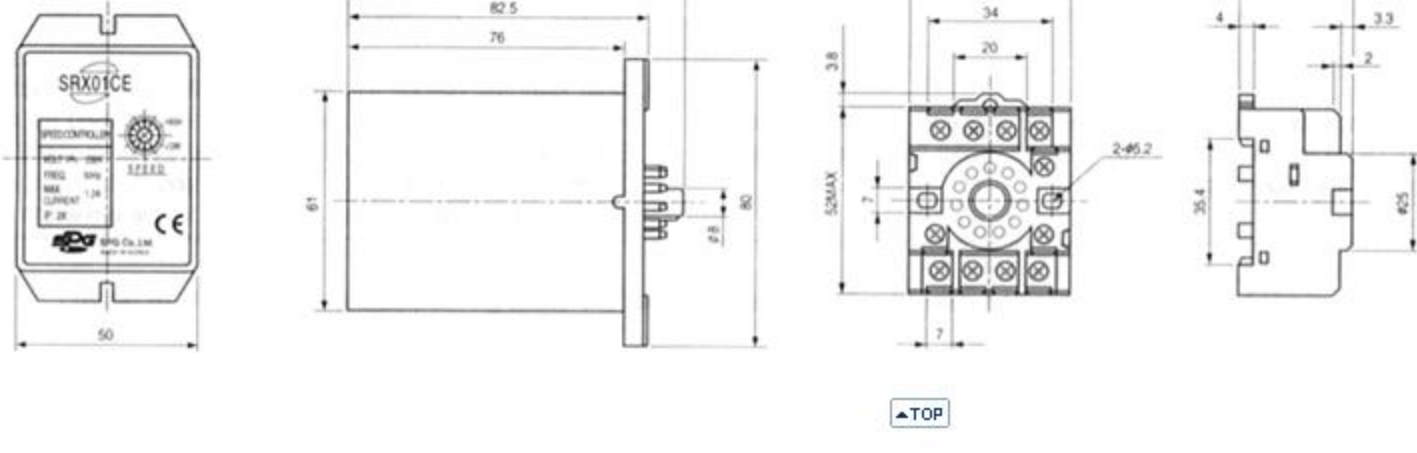

**4. SCHEMATIC DIAGRAM**

**1-1 Uni Direction+Variable Speed**

- INDUCTION MOTOR (6W-90W)
- REVERSIBLE MOTOR (6W-40W)

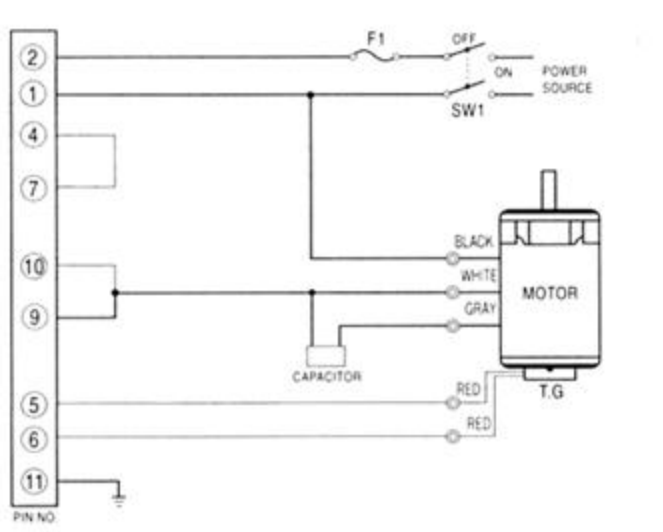

SW1 AC 125V or AC 250V MIN. 5A  
F1 AC 125V or AC 250V 3A

For wiring of 220V-240V, 50Hz motor, change gray to brown.

Note) 1. The motor rotating direction is CW when viewed from output shaft. When adjusting to CCW, change and connect white and gray wire of motor.

2. The connection of a fan motor is applicable only if the output of the motor is greater than 60W and refer to page 175 for the connection method.

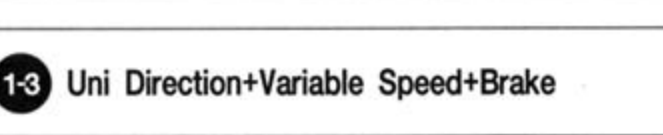

**1-2 Uni Direction+Variable Speed+Brake**

- INDUCTION MOTOR (6W-25W)
- REVERSIBLE MOTOR (6W-25W)

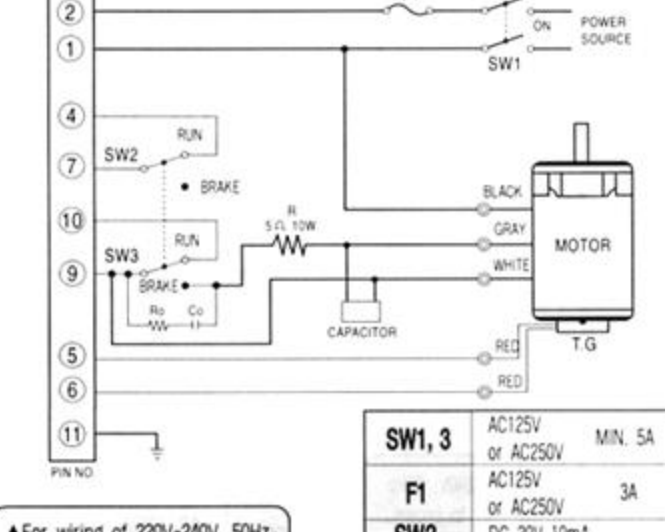

SW1,3 AC125V or AC250V MIN. 5A  
F1 AC125V or AC250V 3A  
SW2 DC 20V 10mA  
Ro,Co Ro=10~200Ω (MIN. 1/4W)  
Co=0.1~0.2μF (AC125V, AC250V)  
R 4.7Ω~6.8Ω MIN. 10W

For wiring of 220V-240V, 50Hz motor, change gray to brown.

Note) 1. The motor rotating direction is CW when viewed from output shaft. When adjusting to CCW, change and connect white and gray wire of motor.

2. When switched from Run to Stop, electric brake will function about 0.5 sec. and motor will come to stop instantaneously.

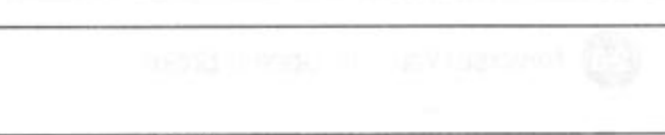

**1-3 Uni Direction+Variable Speed+Brake**

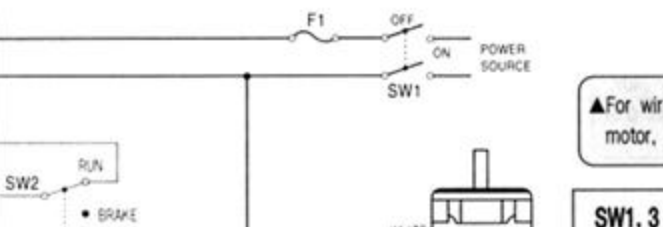

SW1,3 AC125V or AC250V MIN. 5A  
F1 AC125V or AC250V 3A  
SW2 DC 20V 10mA  
Ro,Co Ro=10~200Ω (MIN. 1/4W)  
Co=0.1~0.2μF (AC125V, AC250V)  
R 4.7Ω~6.8Ω MIN. 10W

For wiring of 220V-240V, 50Hz motor, change gray to brown.

Note) 1. The motor rotating direction is CW when viewed from output shaft. When adjusting to CCW, change and connect white and gray wire of motor.

2. When switched from Run to Stop, electric brake will function for 0.5sec. and motor will come to stop instantaneously.

3. The connection of a fan motor is applicable only if the output of the motor is greater than 60W and refer to page 175 for the connection method.

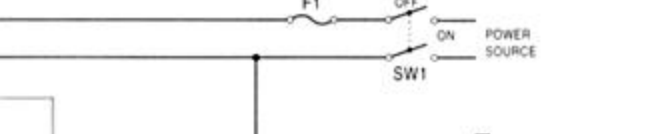

Note) The power switch should be off and check the PIN number when inserting a control pack into socket groove. (There is a possibility to be burned.)

**2-1 Reverse+Variable Speed**

- INDUCTION MOTOR(6W-90W)
- REVERSIBLE MOTOR(6W-40W)

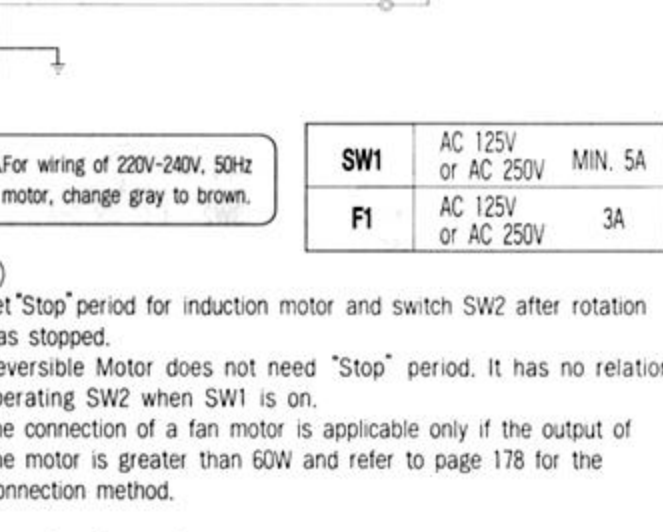

SW1 AC 125V or AC 250V MIN. 5A  
F1 AC 125V or AC 250V 3A

For wiring of 220V-240V, 50Hz motor, change gray to brown.

Note) 1. Set "Stop" period for induction motor and switch SW2 after rotation has stopped.

2. Reversible Motor does not need "Stop" period. It has no relation operating SW2 when SW1 is on.

3. The connection of a fan motor is applicable only if the output of the motor is greater than 60W and refer to page 178 for the connection method.

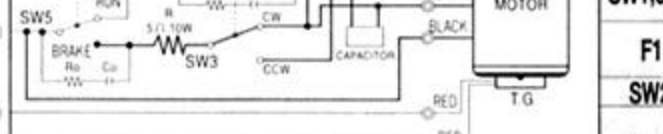

**2-2 Reverse+Variable Speed+Brake**

- INDUCTION MOTOR (6W-25W)
- REVERSIBLE MOTOR(6W-25W)

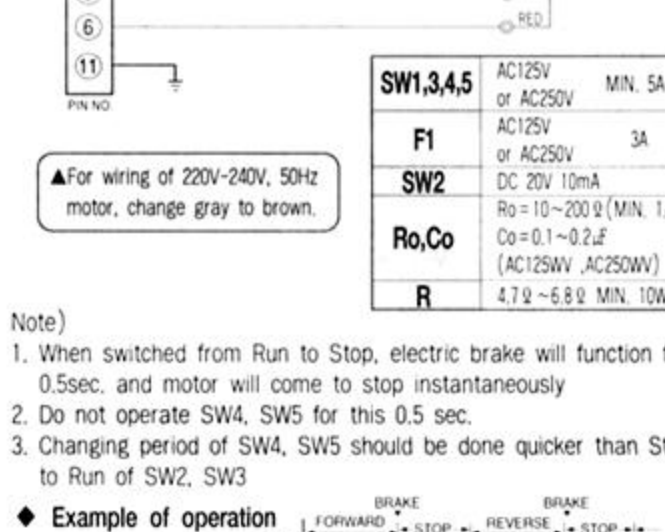

SW1,3,4,5 AC125V or AC250V MIN. 5A  
F1 AC125V or AC250V 3A  
SW2 DC 20V 10mA  
Ro,Co Ro=10~200Ω (MIN. 1/4W)  
Co=0.1~0.2μF (AC125V, AC250V)  
R 4.7Ω~6.8Ω MIN. 10W

For wiring of 220V-240V, 50Hz motor, change gray to brown.

Note) 1. When switched from Run to Stop, electric brake will function for 0.5sec. and motor will come to stop instantaneously

2. Do not operate SW4, SW5 for this 0.5 sec.

3. Changing period of SW4, SW5 should be done quicker than Stop to Run of SW2, SW3

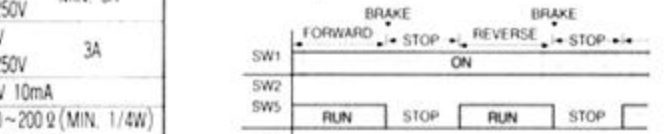

**2-3 Reverse+Variable Speed+Brake**

- INDUCTION MOTOR (40W-90W)
- REVERSIBLE MOTOR (40W)

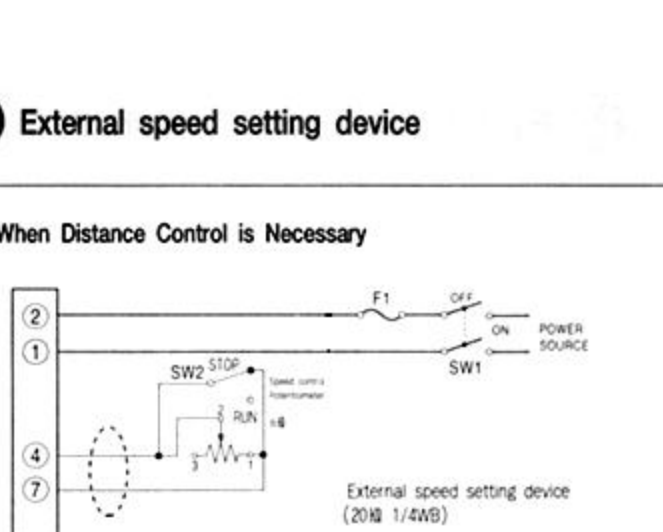

SW1,3,4,5 AC125V or AC250V MIN. 5A  
F1 AC125V or AC250V 3A  
SW2 DC 20V 10mA  
Ro,Co Ro=10~200Ω (MIN. 1/4W)  
Co=0.1~0.2μF (AC125V, AC250V)  
R 4.7Ω~6.8Ω MIN. 10W

For wiring of 220V-240V, 50Hz motor, change gray to brown.

Note) 1. When switched from Run to Stop, electric brake will function for 0.5sec. and motor will come to stop instantaneously

2. Do not operate SW4, SW5 for this 0.5 sec.

3. Changing period of SW4, SW5 should be done quicker than Stop to Run of SW2, SW3

4. The connection of a fan motor is applicable only if the output of the motor is greater than 60W and refer to page 178 for the connection method.

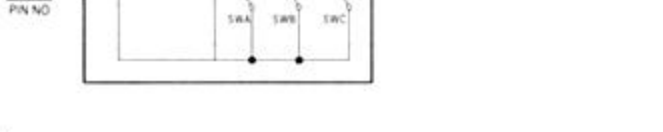

Note) The power switch should be off and check the PIN number when inserting a control pack into socket groove. (There is a possibility to be burned.)

**3-1 External speed setting device**

- When Distance Control is Necessary

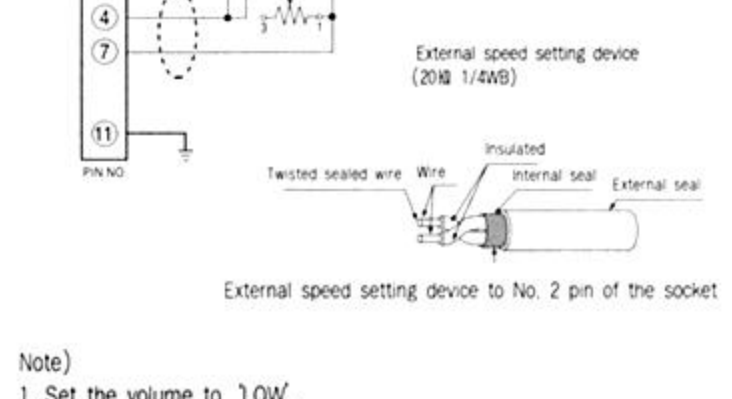

Note) 1. Set the volume to "LOW".

2. Shorten the connection cable as much as possible. May cause faulty action. In such case use twist shield cable and connect it to No.2 terminal.

- When Multi-Stage Speed Setting is Necessary

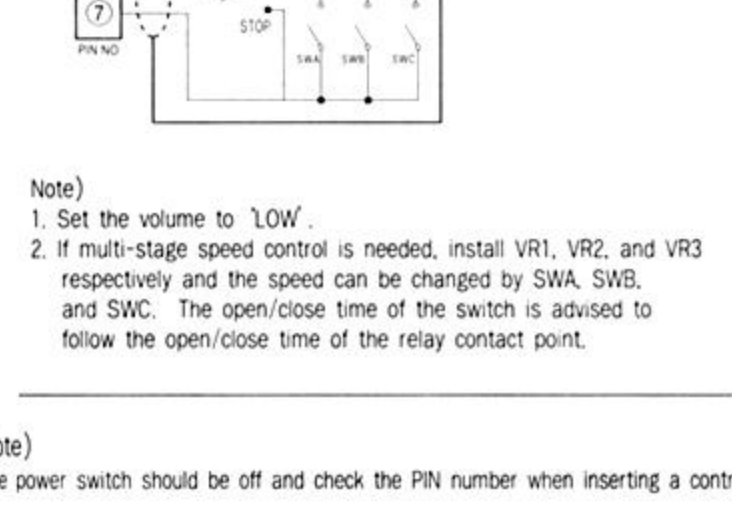

Note) 1. Set the volume to "LOW".

2. If multi-stage speed control is needed, install VR1, VR2, and VR3 respectively and the speed can be changed by SWA, SWB, and SWC. The open/close time of the switches is advised to follow the open/close time of the relay contact point.

Note) The power switch should be off and check the PIN number when inserting a control pack into socket groove. (There is a possibility to be burned.)

**3-2 For prompt start(1)**

- Without braking

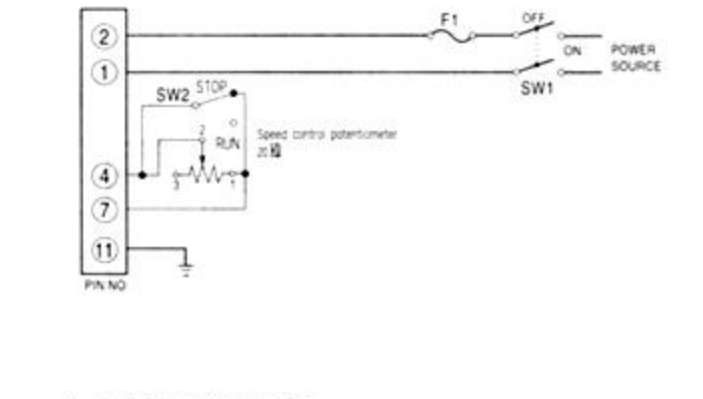

Note) When starting of motor is slow while starting signal is input at Run switch(SW1), use external volume VR at SW2 for Run/Stop.

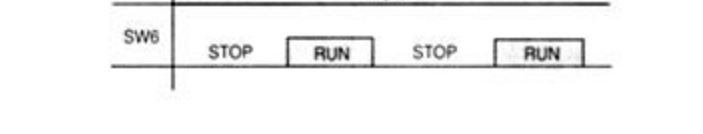

**3-3 For prompt start(2)**

- With Braking

- INDUCTION MOTOR(6W-25W)
- REVERSIBLE MOTOR (6W-25W)

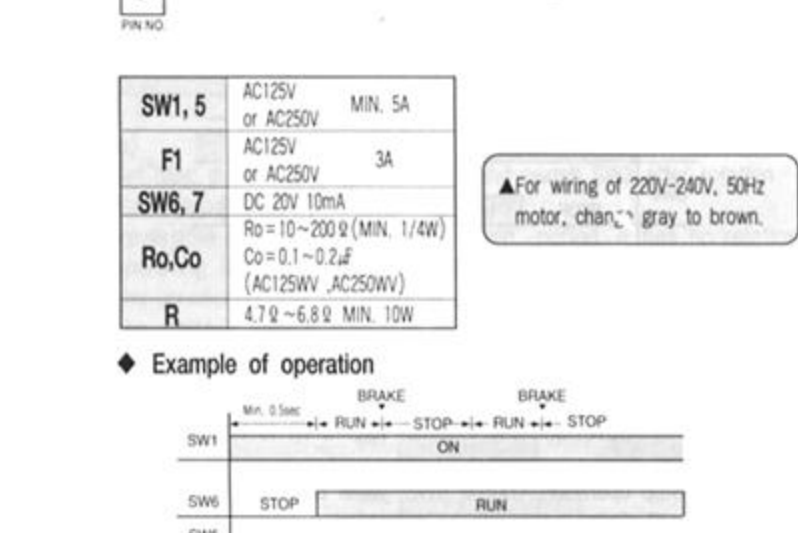

SW1,5 AC125V or AC250V MIN. 5A  
F1 AC125V or AC250V 3A  
SW6,7 DC 20V 10mA  
Ro,Co Ro=10~200Ω (MIN. 1/4W)  
Co=0.1~0.2μF (AC125V, AC250V)  
R 4.7Ω~6.8Ω MIN. 10W

For wiring of 220V-240V, 50Hz motor, change gray to brown.

Note) 1. This wiring is for unidirection+Variable speed+braking of motors 25W or less. For motors 40W and over part of wiring is different. Refer to the electrical wiring diagram for the corresponding connection.

2. Input time of SW1 should be about 0.5sec. quicker than SW6.

3. Set the volume "LOW" and use external volume VR to control speed.

4. When not in use for long period turn SW1 off.



Note) The power switch should be off and check the PIN number when inserting a control pack into socket groove. (There is a possibility to be burned.)

**3-4 Box fan motor connection method**

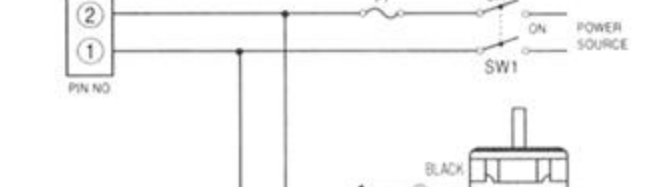

VOLTAGE	LEAD WIRE COLOR
SINGLE PHASE AC100V-110V	BROWN
SINGLE PHASE AC200V-240V	YELLOW

For wiring of 220V-240V, 50Hz motor, change gray to brown.

For the connection of something other than the box fan, refer to the electrical wiring diagram for the corresponding connection.

**4-1 Wire connection for electromagnetic brake motor**

- When electric brake of controller is used at the same time

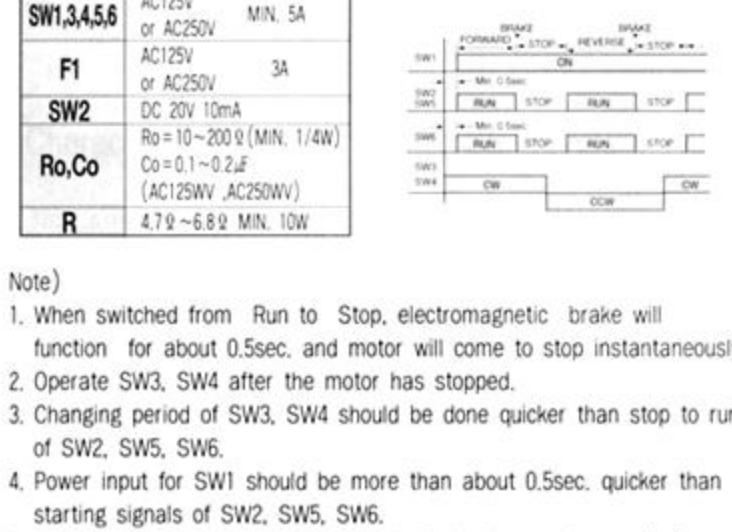

SW1,3,4,5,6 AC125V or AC250V MIN. 5A  
F1 AC125V or AC250V 3A  
SW2 DC 20V 10mA  
Ro,Co Ro=10~200Ω (MIN. 1/4W)  
Co=0.1~0.2μF (AC125V, AC250V)  
R 4.7Ω~6.8Ω MIN. 10W

For wiring of 220V-240V, 50Hz motor, change gray to brown.

Note) 1. When switched from Run to Stop, electromagnetic brake will function for about 0.5sec. and motor will come to stop instantaneously.

2. Operate SW3, SW4 after the motor has stopped.

3. Changing period of SW3, SW4 should be done quicker than stop to run of SW2, SW5, SW6.

4. Power input for SW1 should be more than about 0.5sec. quicker than starting signals of SW2, SW5, SW6.

5. When Run/Stop, operate with SW2, SW5, SW6 while SW1 is 'On' condition. Even with small signal it can control the motor. Turn SW1 off when not used for long period.

**4-2 Wire connection for electromagnetic brake motor**

- When electric brake of controller is used at the same time



SW1,3,4,5,6 AC125V or AC250V MIN. 5A  
F1 AC125V or AC250V 3A  
SW2 DC 20V 10mA  
Ro,Co Ro=10~200Ω (MIN. 1/4W)  
Co=0.1~0.2μF (AC125V, AC250V)  
R 4.7Ω~6.8Ω MIN. 10W

For wiring of 220V-240V, 50Hz motor, change gray to brown.

Note) 1. When switched from Run to Stop, electromagnetic brake will function for about 0.5sec. and motor will come to stop instantaneously.

2. Operate SW3, SW4 after the motor has stopped.

3. Changing period of SW3, SW4 should be done quicker than stop to run of SW2, SW5, SW6.

4. Power input for SW1 should be more than 0.5sec. quicker than starting signals of SW2, SW5&SW6.

5. When Run/Stop, operate with SW2, SW5, SW6 while SW1 is 'On' condition. Even with small signal it can control the motor. Turn SW1 off when not used for long period.

Note) The power switch should be off and check the PIN number when inserting a control pack into socket groove. (There is a possibility to be burned.)

Note) The power switch should be off and check the PIN number when inserting a control pack into socket groove. (There is a possibility to be burned.)

**4-3 Wire connection for electromagnetic brake motor**

- When electric brake of controller is used at the same time



SW1,3,4 AC125V or AC250V MIN. 5A  
F1 AC125V or AC250V 3A  
SW2 DC 20V 10mA  
Ro,Co Ro=10~200Ω (MIN. 1/4W)  
Co=0.1~0.2μF (AC125V, AC250V)

For wiring of 220V-240V, 50Hz motor, change gray to brown.

Note) 1. Set the stop period to stop and convert to SW2 after rotation has stopped.

2. Input period for power switch SW1 should be about 0.5sec. quicker than the signal of start operating of SW6, SW5.



Note) The power switch should be off and check the PIN number when inserting a control pack into socket groove. (There is a possibility to be burned.)

**4-4 Wire connection for electromagnetic brake motor**

- When electric brake of controller is used at the same time



SW1,3,4 AC125V or AC250V MIN. 5A  
F1 AC125V or AC250V 3A  
SW2 DC 20V 10mA  
Ro,Co Ro=10~200Ω (MIN. 1/4W)  
Co=0.1~0.2μF (AC125V, AC250V)

For wiring of 220V-240V, 50Hz motor, change gray to brown.

Note) 1. When Run/Stop, operate with SW2, SW4 while SW1 is on. Even with small signal it can control the motor Turn SW1 off when not used for long period.

2. Set the volume low and control the speed with external speed setting device VR.

3. The connection of a fan motor is applicable only if the output of the motor is greater than 60W and refer to page 178 for the connection method.

Note) The power switch should be off and check the PIN number when inserting a control pack into socket groove. (There is a possibility to be burned.)